



Heetwater hogedrukreiniger

W 5050
W 6000

professional

DSS

TST



	 bar	 l/h	 Kw	 Volt/Hz	 rpm	 °C	 kg	 cm
--	---	---	--	---	---	---	--	--

W 5050	200	1500	12,1	3~400/50	1400	30÷150	231	113x79x94
W 6000	200	1800	14,5	3~400/50	1400	30÷150	274	113x79x94

Heetwater hogedrukreiniger W 5050 - 6000

technische gegevens:

- MEC serie 1400 omw/min onderhoudsvrije inductie motor S1 voor continue gebruik met thermische beveiliging ingebouwd in de wikkelingen.
- 5 meter stroomkabel.
- Glycerine gevulde manometer
- Professionele krukas aangedreven pomp met bronzen pomp kop en drie keramisch plunjers.
- Automatisch kringloopventiel.
- Veiligheidsventiel tegen overdruk.
- Slagvast zeer robuust chassis met ingebouwde reinigingsmiddelen en brandstoftank.
- Regelbare watertemperatuur d.m.v. thermostaat.
- Voorzien van droogkook beveiliging.
- Brandstof niveau controle met waarschuwings led.
- Brandstofpomp: zelfsmerende tandwielpomp.
- Automatische aan/uit schakeling **TST**
- Drop Security System, schakelt de machine uit bij kleine lekkage. **DSS**
- Voorzien van elastische koppeling voor een lange levensduur van motor en pomp

standaard toebehoren:



Hogedrukslang 3/8" lengte 10 meter



Lans met automatisch pistool, totale lengte 800 mm. Het pistool is voorzien van een swivelkoppeling.

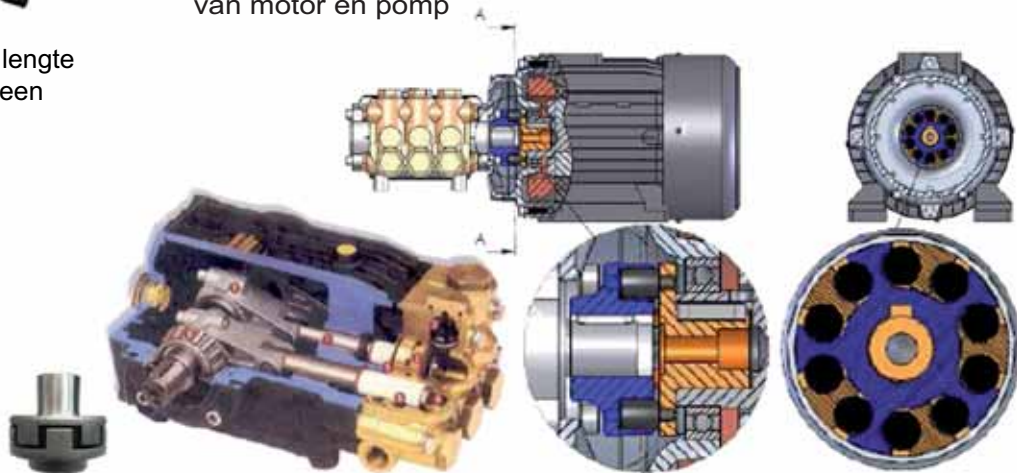
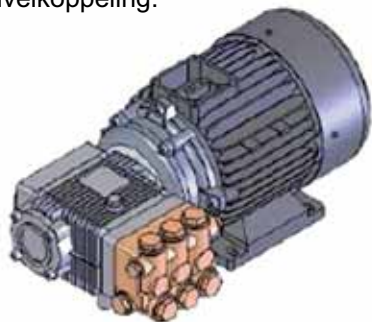

extra accessoires

<p>Dubbele lans</p>	<p>Zandstraalset</p>	<p>Roterende borstel</p>	<p>Roterende sproeier</p>	<p>Surface cleaner</p>
<p>Haspel tbv hd slang</p>	<p>Trekonderbreker</p>	<p>Rioolset</p>	<p>Telescooplans met pistool</p>	
<p>Zwenkarm</p>	<p>Lanshouder</p>			